

PUMP STATION

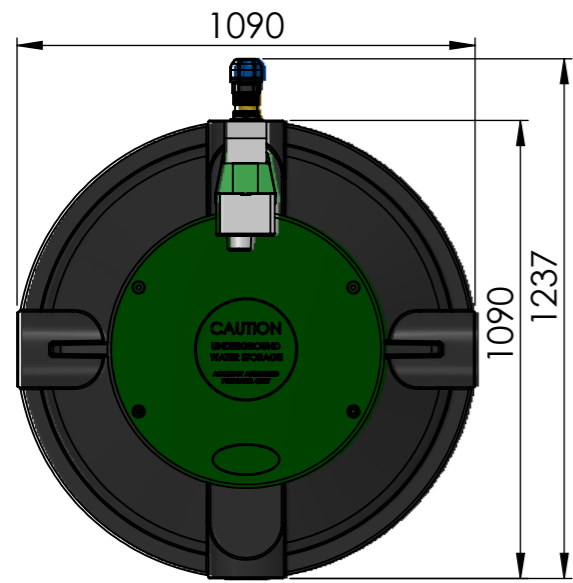

INLET SEAL
SUPPLIED LOOSE

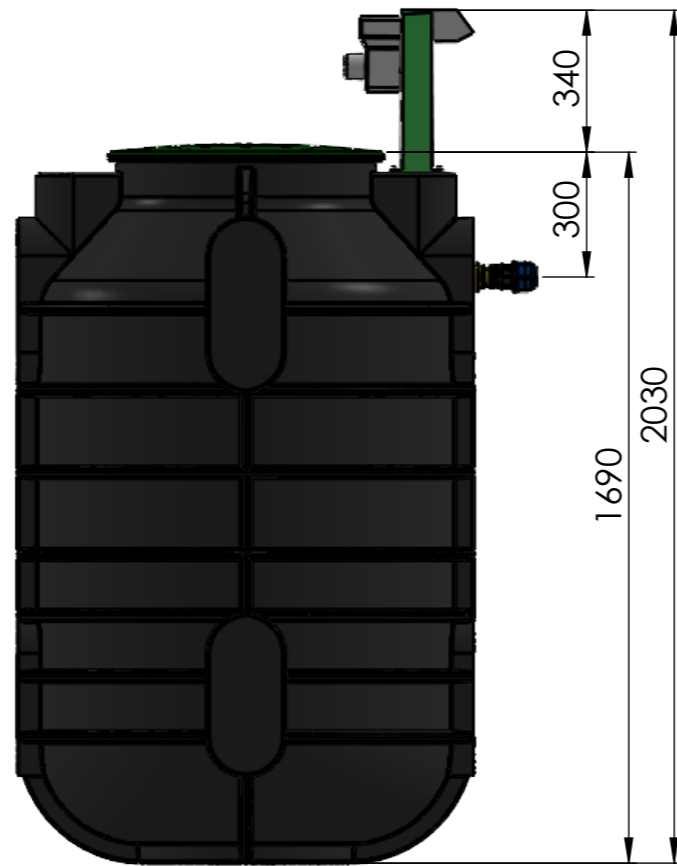
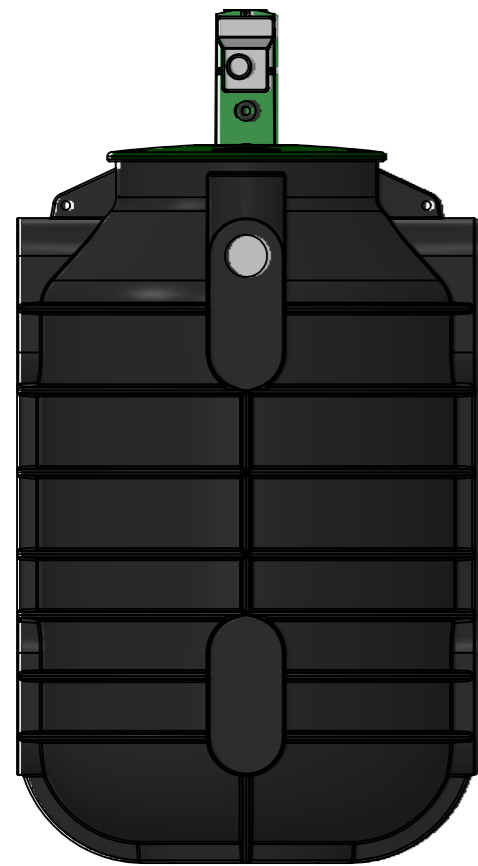

HIGH LEVEL ALARM INDICATOR
COMPLETE WITH WARNING LIGHT & SIREN

DOUBLE POWER POINT
WEATHERPROOF IP66

LID

SWING VALVE

FLOAT SWITCH
WEIGHT

ISOLATING
BALL VALVE

FLOAT SWITCH

OUTLET
COMPRESSION FITTING:
40mm X 1 1/2" BSP

BARREL UNION
ALLOWS FOR QUICK DISMANTLE
AND EASY MAINTENANCE OF PUMP

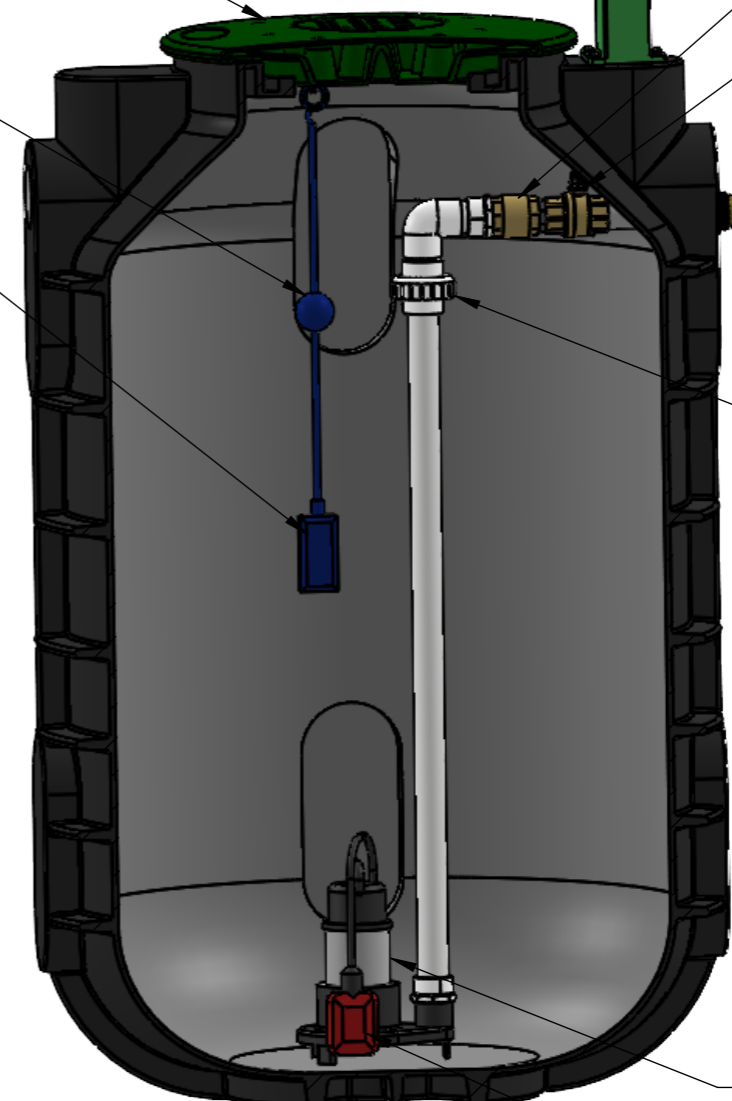

PUMP*
STORMWATER PUMP SHOWN

SECTION THRU TANK SIDE

SCALE 1 : 12

PUMP FLOAT SWITCH

1000L MODEL SHOWN

* DRAINAGE PUMP FOR STORMWATER / GREY WATER
GRINDER PUMP FOR SEWER / BLACK WATER ALSO AVAILABLE

DO NOT SCALE, USE DIMENSIONS. ALL DIMENSIONS ARE IN mm

REV	DRAWN	DATE	PARTICULARS
A	JS	5/03/2024	FIRST RELEASE

Polymaster
161 KARINE STREET
SWAN HILL, VIC
3585
Ph. (03) 5033 9000
Fx: (03) 5033 0224
© POLYMASTER GROUP

DESCRIPTION		OVERVIEW OF PUMP STATION
PRODUCT CODE		PS1000-STM
MATERIAL		
COLOUR		
LEVEL	A	DRAWING No. PS1000-STM-OVERVIEW

SCALE: 1:18	
A3	SHEET SIZE
DRAWN	JS
5/03/2024	1/1 Rev: A