

PUMP STATION

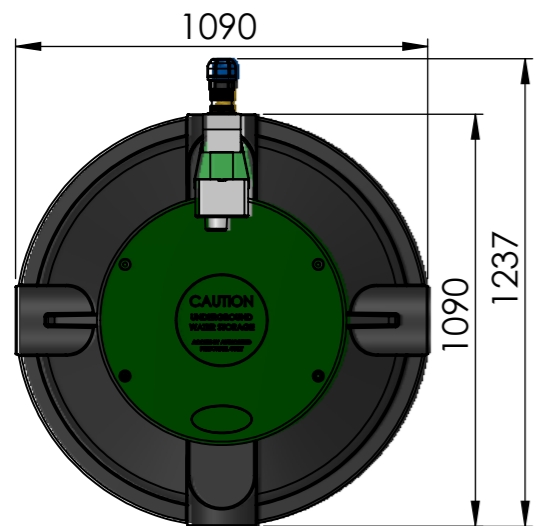

INLET SEAL
SUPPLIED LOOSE

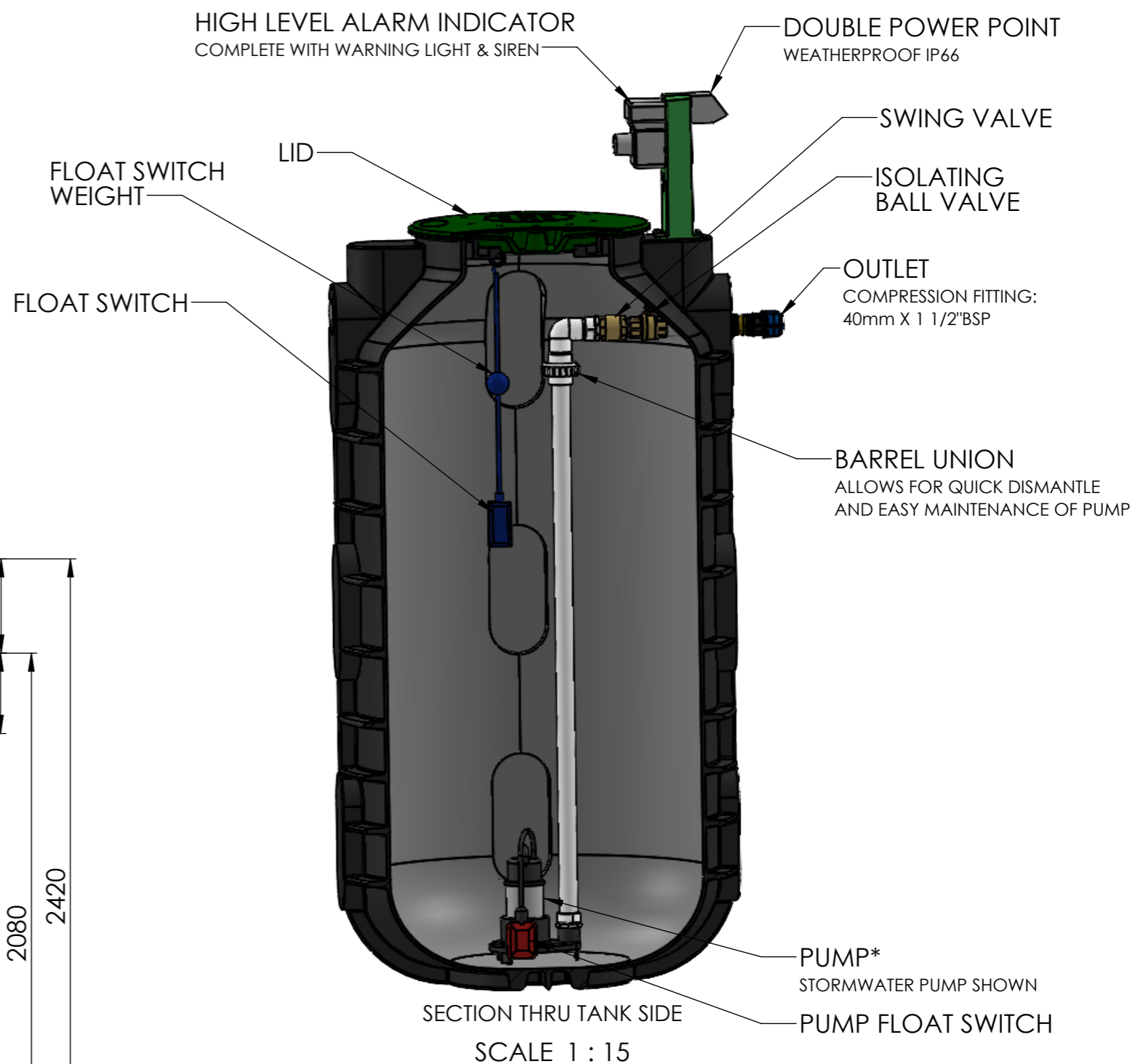
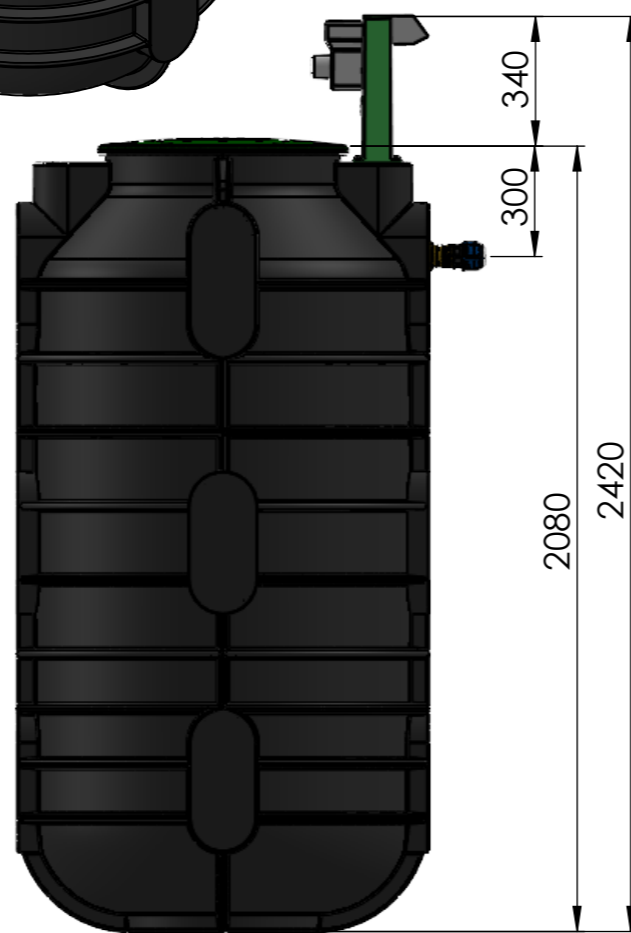
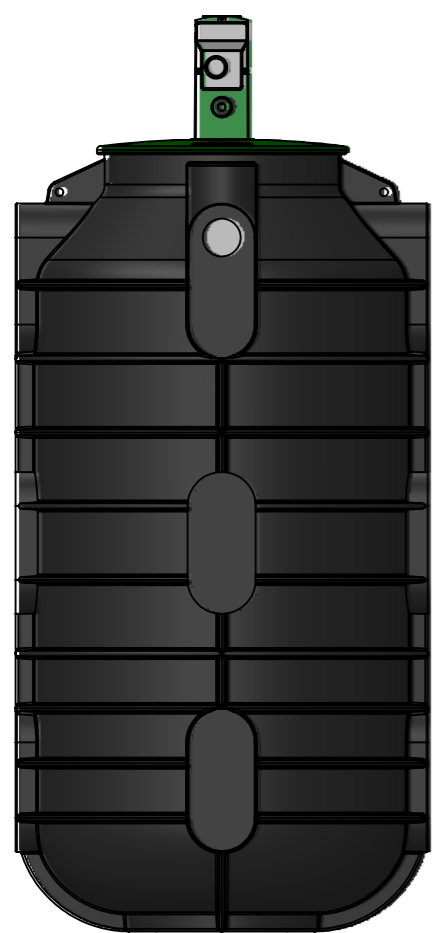

SECTION THRU TANK SIDE
SCALE 1 : 15

1300L MODEL SHOWN

* DRAINAGE PUMP FOR STORMWATER / GREY WATER
GRINDER PUMP FOR SEWER / BLACK WATER ALSO AVAILABLE

DO NOT SCALE, USE DIMENSIONS. ALL DIMENSIONS ARE IN mm

REV	DRAWN	DATE	PARTICULARS
A	JS	5/03/2024	FIRST RELEASE

Polymaster
 161 KARINE STREET
 SWAN HILL, VIC
 3585
 Ph. (03) 5033 9000
 Fx: (03) 5033 0224
 © POLYMASTER GROUP

DESCRIPTION	OVERVIEW OF PUMP STATION
PRODUCT CODE	PS1300-STM
MATERIAL	
COLOUR	
LEVEL	A
DRAWING No.	PS1300-STM-OVERVIEW

DRAWN	JS	5/03/2024	1/1	Rev: A
-------	----	-----------	-----	--------

A3
SHEET SIZE

SCALE: 1:20